

MICROWAVE SENSOR & DIMMING DRIVER

SN-MW736B



Welcome to use SN-MW736B Microwave sensor & Dimming driver

This product is an integration of microwave motion sensor, daylight sensor and LED Dimming driver. It supplies a simple energy-saving solution for LED panel lamp. As all control parts are integrated in a same housing, It is very easy to assemble and save labor cost.

Compact size makes the drivers easy to be installed in luminaries and get more simple lighting structure.

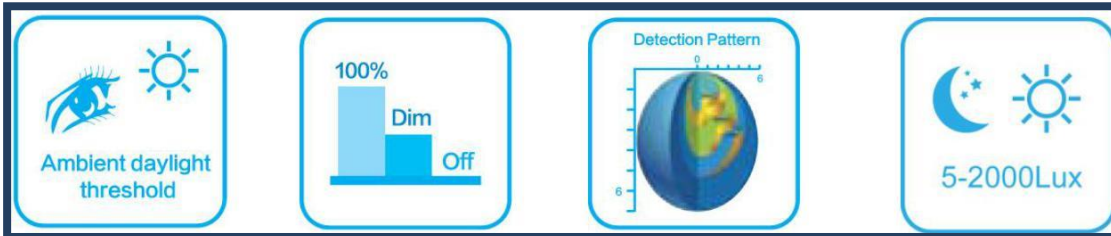

SPECIFICATION:

Power Source: 220 -240V/AC

Power Frequency: 50/60Hz

Detection angle:360°

Detection Range: 10%, 50%, 75%, 100% (choice)

Daylight Sensor: 5lux, 15lux, 50lux, 2000lux (choice)

Detection Distance: 2-8m (radius), adjustable

Transmission Power: <0.2mW

Output Voltage: 35-60V/DC

Output Current: 300mA

Hold Time: 10s, 90s, 3min, 10min (choice)

HF System: 5.8GHz CW radar, ISM band

Power Consumption: approx 0.9W

Installing Height: 2-4m

Detection Motion Speed: 0.6-1.5m/s

Stand-by Period: 0s, 30s, 10min, Stand-by Dimming Level: 20% + ∞ (choice)

SN-MW736B supplies a simple energy-saving solution for LED panel lamp

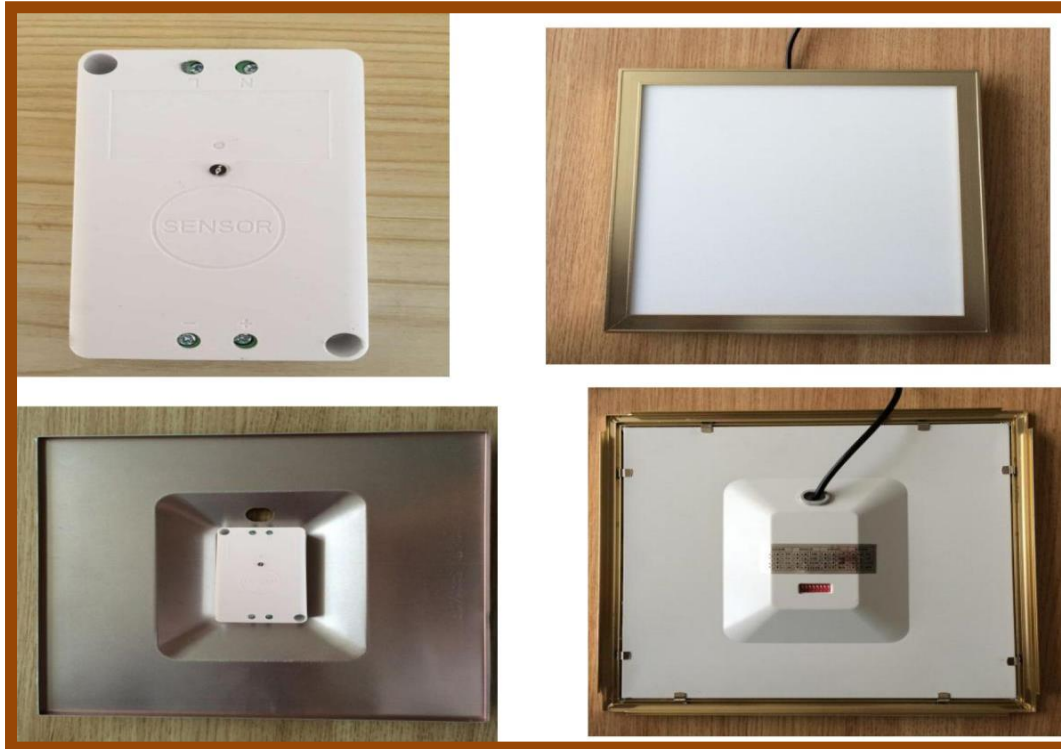

FUNCTION:

- Can identify day and night: It can work in the daytime and at night when two knobs are on above position (Daylight Sensor). It can work in the ambient light less than 5LUX when two knobs are on below position (Daylight Sensor). As for the adjustment pattern, please refer to the testing pattern.
- Hold time is optional. It can be set according to the consumer's desire. The minimum time is 10sec.The maximum is 10min.
- It offers 3 levels of light: 100 %--> dimmed light (20%optional) -->off; and 2 periods of selectable waiting time, motion hold time and stand-by period; selectable LUX value and choice of detection area.



With ambient light more than daylight threshold, the lamp does not switch on when someone enters the room

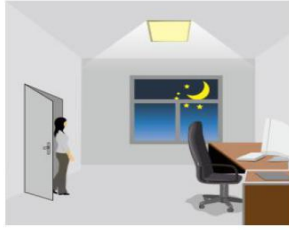

With ambient light less than daylight threshold, the lamp will be on 100% when someone enters the room

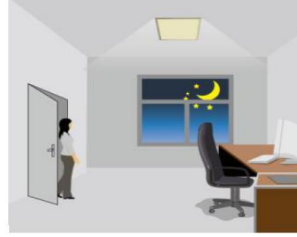

People left, light dims to 20% (optional) stand-by level after hold time

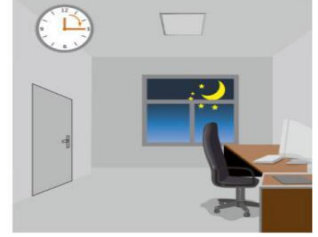

Light switches off automatically after the stand-by period elapsed

SENSOR INFORMATION:

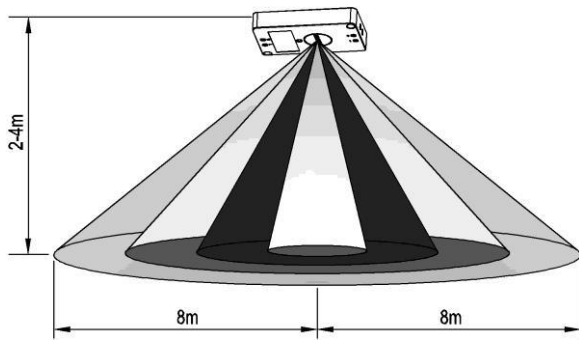

Height of installation 2-4m

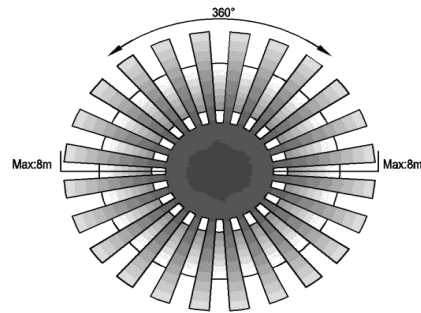

Detection Area: Max. 8m (radius)

SETTING:

Detection Range

Detection distance can be set with different combinations of DIP switches to precisely fit for each specific application

	1	2	
I	●	●	100%
II	○	●	75%
III	●	○	50%
IV	○	○	10%

Hold Time

Hold Time means the time period you would like to keep the lamp on 100% after the person has left the detection distance

	3	4	
I	●	●	10S
II	○	●	90S
III	●	○	3min
IV	○	○	10min

Daylight Sensor

The LUX value can be set on DIP switches in order to fit different ambient light.

	5	6	
I	●	●	2000Lux
II	○	●	50Lux
III	●	○	15Lux
IV	○	○	5Lux

Stand-by Period

This time period you would like to keep at the low light output level before it is completely switched off in the long absence person

Note: “+∞” means fixture keeps on stand-by dimming level and never switches off.

“0s” means no dimming function

	7	8	
I	●	●	0S
II	○	●	30S
III	●	○	10min
IV	○	○	+∞

CONNECTION-WIRE DIAGRAM

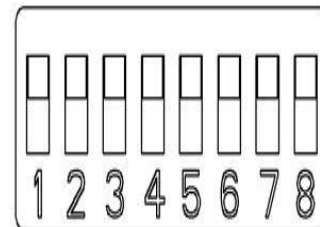
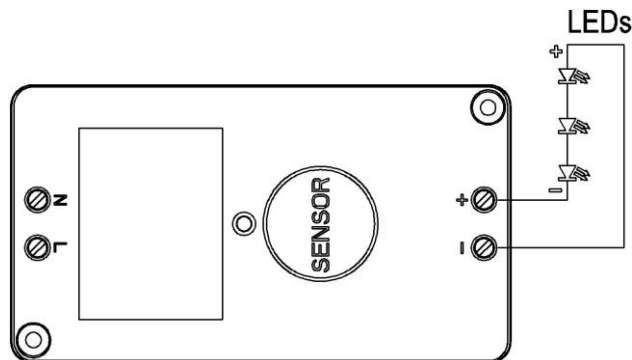

TEST:

- Slide the all knobs on "above" position. When you switch on the power, the light will be on at once, and 10s sec later without induction signal the light will turn off slowly. Then if the sensor receives induction signal, it can work normally
- Adjust the stand-by period to "30s", when the sensor receives induction signal, the light will be 100% on; 10sec later, the light dims slowly to 20% on for 30sec and then turn off. If the sensor receives second induction signal within the stand-by period, the light will be 100% on.

	Detection Range		Hold Time		Daylight Sensor		Stand-by Period				
	1	2	3	4	5	6	7	8			
I	●	●	100%	I	●	●	10S	I	●	●	0S
II	○	●	75%	II	○	●	90S	II	○	●	30S
III	●	○	50%	III	●	○	3min	III	●	○	10min
IV	○	○	10%	IV	○	○	10min	IV	○	○	+∞

Note: when testing in daylight, please slide LUX knob to 2000lux, otherwise the sensor light could not work!

NOTES:

- Electrician or experienced human can install it.
- Can not be installed on the uneven and shaky surface
- In front of the sensor there shouldn't be obstructive object affecting detection.
- Avoid installing it near the metal and glass which may affect the sensor.
- For your safety, please don't open the case if you find hitch after installation.

SOME PROBLEM AND SOLVED WAY:

- The load don't work:
 - a. Check the power and the load.
 - b. Whether the indicator light is turned on after sensing? If yes, please check load.
 - c. If the indicator light is not on after sensing, please check if the working light corresponds to the ambient light.

- d. Please check if the working voltage corresponds to the power source.
- The sensitivity is poor:
 - a. Please check if in front of the sensor there shouldn't be obstructive object that affect to receive the signals.
 - b. Please check if the signal source is in the detection fields.
 - c. Please check the installation height.
- The sensor can't shut automatically the load:
 - a. If there are continual signals in the detection fields.
 - b. If the time delay is set to the longest.

AUTHORISED DISTRIBUTOR ::



ULTRA TECH SECURITY SOLUTIONS

No. 5, G.V.D. Layout, Opp. St., to Chinmaya Vidyalaya, Subramaniya Puram, Coimbatore - 641002.
(Near Nehru Vidyalaya, Robertson Road, R.S.Puram)

E-mail: ultratech.securitysolutions@hotmail.com // ultratechmahaveerjain@gmail.com

Website: www.ultratechsecuritysolutions.com

PH: +91-9443066502 / 9042066502, 0422-3520193

GSTIN NO : 33AAJPJ1987E1ZQ



NO.1, EXPERTS IN METAL DETECTORS & CCTV IN SOUTH INDIA